

# Summer break holiday 's Home work

Class - 6 to 10

Subject Drawing

Take one chart paper sheet or ivory sheet for making a poster /painting on anyone given topic.

\* G20

\* NEP 2020

\* Sports

\* Our culture

\* Happy planet

\*Folk art

\* Art Integrated learning project on any subject

\*Any theme of your choice

ग्रीष्मकालीनअवकाशगृहकार्य  
वर्ष -2023-24

कक्षा- षष्ठी (6)

विषय- संस्कृतम्

1. -निम्नलिखित क्रिया पदानाम द्विवचनं ,बहुवचनं च लिखत ।

(निम्नलिखित क्रिया पदों के द्विवचन ,बहुवचन पदों के रूप लिखो )

पद	एकवचन	द्विवचन	बहुवचन
----	-------	---------	--------

पठति

अपठ त

पठिष्यति

करोति

धावति

2.प्रथमपाठेआगत- सर्वनामपदानांनामानिलिखित्वातदाधारितंषट्वाक्यानांनिर्माणंकुरुत।

(प्रथमपाठमेंआएहुए**सर्वनामपदोंकेनामलिख**करकेउनकेआधारपर 6 सरल  
संस्कृतवाक्योंकानिर्माणकरें)

3.संस्कृतेत्रीणिलिङ्गानि,त्रयः पुरुषाः,त्रीणिवचनानिचकानिसन्ति ,लिखत।

(संस्कृतके 3 लिंग 3 पुरुषऔर 3 वचनकौन-कौनसेहैंलिखिए)

4-वाक्यानि पूरयत-

1- एषः .....|

2- एतौ .....|

3- एते .....|

4- .....पठति |

5- .....पठसि |

6- .....पठामि |

7- .....पठवः |

8- .....पठामः|

9- .....पठथः |

10- .....पठथ |

5- संस्कृत भाषायाम प्रार्थना ,प्रतिज्ञा च लिखत |

( संस्कृत भाषा में प्रार्थना वप्रतिज्ञा लिखो )

द्वारा -

जयंती सयाना

ग्रीष्मकालीनअवकाशगृहकार्य  
वर्ष -2023-24

कक्षा- सप्तमी (7)

विषय- संस्कृतम्

1. निम्नलिखितपदानां पदपरिचयं लिखत-

पदम् - विभक्ति वचनम्

1. यथा- पृथिव्यां सप्तमी एकवचनम्

i. कच्छपः .....

ii. रविः - .....

iii. विद्यायाः .....

iv. क्षमया - .....

v. -हंसौ .....

2. किम् शब्दस्य रूपाणि त्रिषुलिङ्गेषु लिखत।

(किम् शब्द के रूप तीनों लिंगों में लिखिए)

3. प्रथमपाठस्य श्लोकान्स्मृत्वा स्वअभ्यासपुस्तिकायां लिखत।

(प्रथमपाठ के श्लोकों को याद करके अपनी अभ्यास पुस्तिका में लिखिए)

4. संस्कृतभाषायाः महत्त्वं पञ्चवाक्येषु लिखत।

(संस्कृतभाषा के महत्त्व के विषय में पांच वाक्य लिखिए)

5- दश शरीरस्य अंगानाम् चित्रं कृत्वा नमानि लिखत ।

(दश शरीर के अंगों के चित्र बनाकर नाम लिखो )

6- संस्कृत भाषायाम् प्रार्थना , प्रतिज्ञा च लिखत ।

( संस्कृत भाषा में प्रार्थना व प्रतिज्ञा लिखो )

द्वारा – जयंती सयाना

ग्रीष्मकालीन अवकाशगृहकार्य

वर्ष -2023-24

कक्षा- अष्टमी (8)

विषय- संस्कृतम्

1. प्रथमपाठस्य श्लोकान्स्मृत्वा स्वअभ्यासपुस्तिकायां लिखत।

(प्रथमपाठ के श्लोकों को याद करके अपनी अभ्यासपुस्तिका में लिखिए)

2- महाकवि कालीदास .संसर्गस्य प्रभाव : ,मम विद्यालय : इति -विषये पञ्च -पञ्च वाक्यानि लिखत।

(महाकवि कालीदास .संसर्गस्य प्रभाव ,मेरा विद्यालय के विषय में पांच-पांच वाक्य लिखिए)

3. अस्मद् तथा युष्मद् शब्दस्य रूपम् स्मरत लिखत च ।

{ अस्मद् तथा युष्मद् शब्दरूप याद करें तथा लिखें }

4- संस्कृत भाषायाम् प्रार्थना ,प्रतिज्ञा स्मरत लिखत च ।

( संस्कृत भाषा में प्रार्थना तथा प्रतिज्ञा याद करें तथा लिखें )

द्वारा – जयंती सयाना

## Summer Vacation Holiday H.W

English

VIII-A

- 1) Read all the chapters carefully of both your books.
- 2) Write a Travelogue in about 100 i120 words describing your experiences of your journey to a tourist place during the vacations.
- 3) Write a short story of atleast 150-200 words based on your imagination.
- 4) Read any ONE BIOGRAPHY from the list given below:
  - 1) Mahatma Gandhi
  - 2) Nelson Mandela
  - 3) Dr A.P.J.Abdul Kalam
  - 4) Kiran Bedi
  - 5) Maharana Pratap
  - 6) Shiva ji Maharaj
  - 7) Abraham Lincoln
- 5) You saw children (below the age of 14 yrs) working on stalls, pavements,tea-shops e.t.c You are deeply touched to see their plight.Write a diary entry about it.
- 6) Complete the written work of both the books.
- 7) Listen to B.B.C News daily and pay attention to the pronunciations.
- 8) Read English newspaper daily – specially the Editorial Essays and Articles.
- 9) Write a letter to the Editor on.....
  - A)Problem of scarcity of water supply in your locality
  - B) Problem of Traffic Jams in your city
- 10).Write a letter to your friend:-
  - A) Emphasising the importance of doing 'YOGA'
  - B) Time Management
  - C). Importance of playing Games and Sports
  - D) I'll effects of excessive use of Mobile Phones.

## SUMMER HOLIDAYS HOMEWORK YEAR 2023 - 24

1. History lesson No. 1 (Exercise write and learn)
2. Geography lesson No. 1 (Exercise write and learn)
3. Civics lesson No. 1 (Exercise write and learn)
4. Geography, History & Civics lesson No. 2  
(Read and make the notes)
5. Write about all the fundamental rights
6. In political Map of India Show the all States and Capital
7. In project work : Learner's Diary

## **CLASS-VIII, HOLIDAY HOMEWORK (ENGLISH)**

**Do HHW in your English notebook. Do Not use a separate notebook.**

1. Read the 2nd, 3rd and 4th chapters of "It So Happened" and note down the difficult words and their meanings in your notebook. (Use dictionary)

2. **LEARNER'S DIARY** (1. What did I learn from the chapter ? 2. What Did I find most challenging in the chapter ? 3. What was the most interesting thing in the chapter ?)

Prepare LEARNER'S DIARY on the following lessons, by answering the above given three questions:

- (i) The best Christmas present in the world
- (ii) The tsunami
- (iii) The ant and the cricket
- (iv) How the camel got his hump

### **3. Diary Entry**

Suppose you were one of the victims of Tsunami. Write a diary entry for the same.

### **3. MDP (PROJECT WORK) ( To be done in a file)( Paste pictures also)**

#### **TOPIC -**

- Write a brief note on the International Year of Millets.
- Give a brief description of various kinds of millets found in India
- Importance of Millets.

#### **INSTRUCTIONS:**

- 1 Project is to be prepared in a file.
2. Your full name and class must be written CLEARLY on the cover.
3. Make the cover attractive.
4. Index/ Table of Contents. '
5. Each item must begin on a fresh page.
6. Put a Bibliography at the end.
7. Overall presentation: layout/ neatness/ grammar, spellings/ illustrations/ handwritten.
- 8.Final projects MUST be written LEGIBLY

4. G-20 - Read the following conversation on G-20 and answer the questions given at the end.

# **Let us learn about Group of Twenty (G 20)**

**A Reading for Students of Classes VI, VII and VIII**





# Ministry of Education Government of India

## Let us learn about Group of Twenty (G 20)

Here is a conversation on Group of Twenty (G20) in which Kannan, Aastha and their teacher Mrs. Ekta are deliberating about G 20, its roles and India's presidency this year. Let us read their conversation.

**Aastha:** Namaskar! Kannan and Namaskar Madam! How are you?

**Kannan:** Namaste! I am fine. How are you, Aastha?

**Mrs. Ekta:** Namaskar. I am doing well. How are you?

**Aastha:** Madam, I would like to know about G20. I read in the newspaper and watched on television news about it. **India has taken over the presidency of G20. Our Prime Minister assumed as the chair of G 20.**

**Mrs. Ekta:** Yes Aastha, You should first know that India is the Fountain Head of Democracy and the first Republic of the world originated in the Ancient India. G20 forum gives India the unique opportunity to communicate its democratic ethos to the world specially during th presidency of G 20..

**Kannan:** Wow. Like Aastha, I too want to learn about G20.

**Mrs. Ekta:** That is good. I am very happy that you are aware of what is happening around the world. This curiosity and interest, I like it. Fine. Let me ask you a question before I tell you about G 20. Do you know the expansion of G20?

**Kannan:** Yes I know. It is 'Group of Twenty'?

**Aastha:** Yes. I too know it. Is it because twenty countries are members of G20?

**Mrs. Ekta:** Are all 20 of them countries or any organizations or group of countries are also in it?

**Kannan:** Yes. I think all of them are countries.

**Mrs. Ekta:** No. There are **19 countries** and one union of countries known as **European Union**. We will understand this further. Now let us know what G20 is; why it was created and so on.

**Kannan:** Yes madam. Tell us about it.

**Mrs Ekta:** The G20, or Group of Twenty, is a forum for international economic cooperation and mutual understanding. It is an **intergovernmental forum** of the world's 20

major developed and developing economies. Intergovernmental means two or more governments. You see there are governments of 19 countries and there is European Union which is another forum of most countries of Europe.

**Aastha:** Oh! This is great – a forum of many countries. Madam I have a question. You said that it is an intergovernmental organization which we understand. You also said that it is a forum for 20 major **developed and developing economies**. What is this, ‘developed’ and ‘developing’ countries?

**Kannan:** Yes. Could you please tell us about it?

**Mrs. Ekta:** You know some of the countries in the world have economically grown over a period and they have material wealth, high standard of living, and they are engaged in lots of trading activities. They are known as developed countries. Most people in the developed countries earn higher incomes when compared to developing countries. This forum of G20 has both developed countries and developing countries. This is to bridge the gap between these two categories of countries. You can see this. The 19 countries are from all the continents except Antarctica (where there is no human population living) of the world. Here is a list of countries Aastha and Kannan. You read it out for yourself.

**Aastha and Kannan:** Yes madam. Here are the countries. It is given in alphabetical order **Argentina, Australia, Brazil, Canada, China, France, Germany, India, Indonesia, Italy, Japan, Republic of Korea, Mexico, Russia, Saudi Arabia, South Africa, Turkey, United Kingdom and United States, and the European Union.**

**Kannan:** Let me check which country from Africa is member of G 20. Yes. It is South Africa.

**Aastha:** Let me tell you which are the countries from Asia, our continent, India, China, Indonesia, Japan, Republic of Korea, Saudi Arabia and Turkey.

**Kannan:** Yes. But Turkey is both in Asia and in Europe.

**Aastha:** Yes. Like Russia which is spread across Asia and Europe.

**Mrs. Ekta:** So, Can we say it is truly a global forum of economic and political cooperation?

**Aastha:** Yes. It is truly a global forum.

**Kannan:** So it is a historic moment and a proud moment for all of us in India that India has assumed the G20 Presidency.

**Mrs. Ekta:** Yes, definitely. Do you know that India has assumed the Chair from 1<sup>st</sup> December 2022 till 30<sup>th</sup> November 2023?

**Kannan:** Yes. Let me ask you madam, When was it started? How and why this G20 began?

**Mrs. Ekta:** I like your interest. Let me tell you. The G20 was founded in 1999 after the Asian financial crisis as a forum for the Finance Ministers and Central Bank Governors to discuss global economic and financial issues. There was a financial crisis affecting Asian countries and this G20 was formed to address the economic crisis. Notice, that it started as a forum of Finance Ministers and Governors of Central Banks. Central Bank is the Reserve Bank in India. In the year 2007, G20 was upgraded to the level of Heads of Countries /Government when there was a global economic and financial crisis which affected all the countries of the world. G20 was designated the ‘**premier forum for international economic cooperation**’ in the year 2009. It became a truly a global forum for economic cooperation and mutual understanding and support.



**Kannan:** Oh! Thank you, madam. This is interesting. It has grown into a global forum to benefit all.

**Aastha:** I am rather excited to learn about the G20’s transformation. Madam there is a logo for G20. Could you please tell us about the G20 logo?

**Mrs. Ekta:** You can see it here . G2 with earth in place of zero on the lotus, our national flower. Under this is **Bharat in Hindi, 2023 and India**. International cooperation is gaining greater prominence as the world is integrating more and more due to economy and digital technology. However, India is imbued with this spirit since more than 3000 years and has been always at the forefront of cooperation. Below the logo is the inspiring quote from the ancient Sanskrit text, *Maha Upanishad Vasudhaiva Kutumbakam- One Earth One Family One future*. This is India’s message to the world through G20 that ‘**the World is one**

**family**'. This theme makes it relevant to today's world as conflicts and war in many countries, poverty and other problems are affecting lives of people and community as a whole.



वयुधेव कुदुम्बकम्

ONE EARTH • ONE FAMILY • ONE FUTURE

The G20 Logo draws inspiration from the vibrant colours of **India's national flag – saffron, white and green, and blue. It juxtaposes planet Earth with the lotus, India's national flower that reflects growth amid challenges.** Theme affirms the value of all life –human, animal, plant, and microorganisms – and their interconnectedness on the planet Earth and in the wider universe.

**Aastha:** This is both interesting and inspirational. I feel proud as an Indian.

**Kannan:** I too feel the same, a proud Indian.

**Mrs. Ekta:** Let me also tell you a bit more about the theme of the G 20 Logo. The theme also spotlights LiFE (Lifestyle for Environment), with its associated, environmentally sustainable and responsible choices, both at the level of individual lifestyles as well as national development, leading to globally transformative actions resulting in a cleaner, greener and bluer future.

**Aastha:** Oh! I see. This is much more needed for young people like us. We need to preserve our environment.

**Mrs. Ekta:** Let me also share with you that the concept of LiFE (Life Style For Environment) was enunciated by our Prime Minister Shri Narendra Modi at Glasgow in the Conference of Parties (CoP 26) in 2021. Something more about G20 and how it is important for India. You know very well that we are celebrating 75 years of our independence. For India, the G20 Presidency also marks the beginning of 'Amritkaal', the 25-year period beginning from the 75th anniversary of its independence on 15 August 2022, leading up to the centenary of its independence, towards a futuristic, prosperous, inclusive and developed society, distinguished by a human-centric approach at its core, the centre.

**Kannan:** That is really exciting! I am looking forward to see how these are realized.

**Aastha:** Yes. This makes me ask you madam, another question. What are the activities and events India is organizing as part of the G20?

**Mrs. Ekta:** There are lots of activities for everyone to participate and contribute. India will host over 200 meetings in over 50 cities across 32 different work streams i.e. themes and area of work. Through these meetings we will have the opportunity to offer G20 delegates and guests from the G20 countries and also from Guest countries a glimpse of India's rich cultural heritage and provide them with a unique Indian experience.

**Aastha:** You said some countries are invited as guest countries. Tell us about it later. Now let me ask a question, "Do we, school, students have any activities?"

**Kannan:** I am eager to participate.

**Mrs. Ekta:** Yes. There are many activities and events for school and university students. There are some activities already launched / started. You can participate in them. There are two Quiz competitions –one on general awareness about G20 and the other on Life Style for Environment Quiz. These two quizzes have been already launched and are available on <https://quiz.mygov.in> One slogan writing competition has also been launched. You can see that online and write a slogan on G20 and its various aspects.

**Kannan:** I will definitely participate.

**Aastha:** I too will do it, right now.

**Mrs. Ekta:** Many more events are scheduled for the whole year. Augmented Reality (AR) and Virtual Reality (VR) exhibitions for school learners. Science Exhibition will also be held at different locations shown in the schedule of activities. You can refer to them on the dedicated G20 website [g20.org](http://g20.org) and from Ministry of Education, Government of India's website and also from NCERT website <https://ncert.nic.in>

Aastha and Kannan, I told you that there some countries invited as guest countries. Let me tell them about these countries. The guest countries are: Our neighbor, Bangladesh, Egypt, Mauritius, Netherlands, Nigeria, Oman, Singapore, Spain and United Arab Emirates (UAE)

### Guest Countries



**Aastha:** It is again countries from all over the world.

**Kannan:** Great! Bringing all the countries means bring the peoples of the world together to lead a harmonious life.

**Mrs. Ekta:** Absolutely! Let me also tell you. There are many international organizations like the United Nations will also participate in the G20 activities during India's presidentship.

**Aastha:** Fine. Which are the organizations?

**Mrs. Ekta:** Kannan, Can you guess?

**Kannan:** I know that UNO would be there. But....

**Mrs. Ekta:** Yes. You are right. But many more organizations are participating as invitees in the G20 activities. These include: United Nations, International Monetary Fund (IMF), World Bank (WB), World Health Organization (WHO), World Trade Organization (WTO), International Labour Organization (ILO), Financial Stability Board (FSB) Organization for Economic Co-operation and Development (OECD) and many more regional organizations like Asian Development Bank (ADB).

**Aastha and Kannan:** Thank you madam for making us understand and aware of G20 and its role and function, how India's presidency is important for India as well as other countries of the world.

**Mrs. Ekta:** Fine. You are welcome. Let me also tell you something that India offers and makes this year's G20 events and India's Presidency unique and distinct is that **India's G20 Presidency will be taking the G20 closer to the public and making it truly a 'People's G20'**. To realize this, Citizen engagement and large scale public participation through various **Jan Bhagidari activities are planned throughout the year**. This is the vision of India's Prime Minister, Shri Narendra Modi.

**Aastha and Kannan:** Thank you madam.

**Mrs. Ekta:** You are welcome. Let me give you two tasks for both of you. First as you promised, to participate in the quiz and slogan competition.

The other task is to visit G20 website <https://www.g20.org> and read about the countries and their socio, economic and cultural aspects.

**Aastha and Kannan:** Sure madam. Will do.

**Learners, how was the conversation on G20? Have you also learnt about G20? Here are some questions for you and attempt them based on your reading of the conversation.**

1. Why was G20 created?
2. Who from the member countries participated in the beginning of G20?

3. Who is the President of G20 now?
4. What does the G20 Logo convey?
5. Write a letter to a student like you in one of the G20 countries describing about our country, your town/ village / city and how the people are, the festivals and so on.



SUMMER VICATION HOLIDAY HOME-WORK

Q1- Answer the following question

- Why did British preserve official documents?
- In which year the battle of Plassy happen?
- Who was called The Tiger of Mysore?
- Who was Haider Ali?
- Explain the system of “subsidiary Alliance”
- What was Lord Dalhousie’s doctrine of lapse?
- Why are resources distributed unequally over the Earth?
- What is resource development?
- What is sustainable development?
- What is the difference between potential and actual resources?

Q2-Make learners diary for 1 term

Geography – lesson 1,2

Civics– lesson 1,2,3,4,5

History- 1,2,3,4f

Locate and label the following map form of

dance with states of India on the map-

(i) Sattriya

(ii) Mohiniattam (iii) Bharatnatyam

(iv) Kuchipudi (V) Kathak (vi) Kattu kathakali Odissi

(vii) Odissi

Lavani & Dindi

(ix) Ghoomar

(x) Biku.

# केंद्रीय विद्यालय ओएनजीसी देहरादून

ग्रीष्मकालीन अवकाश गृहकार्य 2023-24

विषय - हिंदी

कक्षा - आठ

1. 'लाख की चूड़ियां' और बस की यात्रा के सभी प्रश्नोत्तर लिखें व याद करें ।
2. कोई भी एक देशभक्ति पूर्ण अथवा प्रेरणादायक हिंदी कविता तथा कोई एक हिंदी कहानी याद करें ।
3. अनुच्छेद लिखें :- क. विद्यार्थी जीवन और अनुशासन ख. भारत के विकास में युवाओं का योगदान ग. अपनी भाषा प्यारी भाषा घ. ग्लोबल वार्मिंग (80 से 100 शब्दों में)
  4. पर्यावरण संरक्षण को लेकर दो मित्रों के बीच कम से कम 30 वाक्यों में संवाद लिखिए ।
  5. अपने छोटे भाई या बहन समय के सदुपयोग की सीख देते हुए पत्र लिखिए ।
  6. शिक्षार्थी डायरी- आपके पाठ्यक्रम के पाठ 1 से 5 पढ़ें और उसके आधार पर शिक्षार्थी डायरी निम्न बिन्दुओं के आधार पर लिखें:-
    1. पाठ का सार ।
    2. आपको पाठ में क्या सबसे अच्छा लगा और क्यों?
    3. आपको पाठ पढ़ते और समझते समय क्या क्या परेशानी हुई?
    4. आपको इस पाठ से क्या सीखने को मिला?
  7. कोई भी एक प्रेरणादायक पुस्तक पढ़ें और उसकी समीक्षा निम्न बिन्दुओं के आधार पर करें:-
    - i) पुस्तक की प्रस्तावना लिखें।
    - ii) पुस्तक का सारांश लिखें।
    - iii) पुस्तक के मुख्य पात्र।
    - iv) पुस्तक में सबसे अधिक आपको किसने प्रभावित किया और क्यों?
    - v) इस पुस्तक से आपको क्या शिक्षा मिली?
  8. भारत की खोज किताब के पहले तीन पाठ पढ़ें और मुख्य बिंदुओं को नोट करें।

आप सभी स्वस्थ रहें , मस्त रहें , खुश रहें , सीखते रहें ,

नोट: विद्यालय ई पत्रिका हेतु सभी विद्यार्थी स्वरचित कविता, लेख इत्यादि अनिवार्य रूप से लेकर आएंगे ।

स्वस्थ रहो मस्त रहो ।

# MATHS HOLIDAY HOMEWORK FOR SUMMER VACATION

2023-24

CLASS: 8

Q1. Write the definitions of:

- a) Natural Numbers
- b) Whole numbers
- c) Integers
- d) Rational numbers

In support of your answer, also represent a few of each type on a number line.

Q2. Mention the commutativity, associative and distributive properties of rational numbers. Also, check  $a \times b = b \times a$  and  $a + b = b + a$  for  $a = \frac{1}{2}$  and  $b = \frac{3}{4}$

Q3. Write any 5 rational numbers between  $-\frac{2}{5}$  and  $\frac{1}{2}$ .

Q4. Represent  $-\frac{2}{11}$ ,  $-\frac{5}{11}$ , and  $-\frac{9}{11}$  on the number line.

Q5. A positive number is 5 times another number. If 21 is added to both the numbers, then one of the new numbers becomes twice of the other new numbers. Find the original numbers.

Q6. The sum of three consecutive multiples of 8 is 888. Find the multiple.

Q7. Five years ago, Anu was thrice as old as Sonu. After ten years, Anu will be twice as old as Sonu. How old are Anu and Sonu?

Q8. Three consecutive integers are as such they are taken in increasing order and multiplied by 2, 3, and 4 respectively, they add up to 56. Find these numbers.

Q9. There is a narrow rectangular plot. The length and breadth of the plot are in the ratio of 11:4. At the rate of Rs. 100 per meter it will cost village panchayat Rs. 75000 to fence the plot. What are the dimensions of the plot?

Q10. Convert the following statements into equations.

(a) 3 added to a number is 11

(b) 2 subtracted from a number is equal to 15.

(c) 3 times a number decreased by 2 is 4.

(d) 2 times the sum of the number  $x$  and 7 is 13.

Q11. The sum of three consecutive odd numbers is 51. Find the numbers.

Q12. A sum of Rs.2700 is to be given in the form of 63 prizes. If the prize is of either Rs.100 or Rs.25, find the number of prizes of each type.

Q13. The angles of a quadrilateral are in the ratio of 1:2:3:4. What is the measure of the four angles?

Q14. In quadrilaterals,

(i) which of them have their diagonals bisecting each other?

(ii) which of them have their diagonal perpendicular to each other?

(iii) which of them have equal diagonals?

Q15. Find the angle measure  $x$  in the following figures.

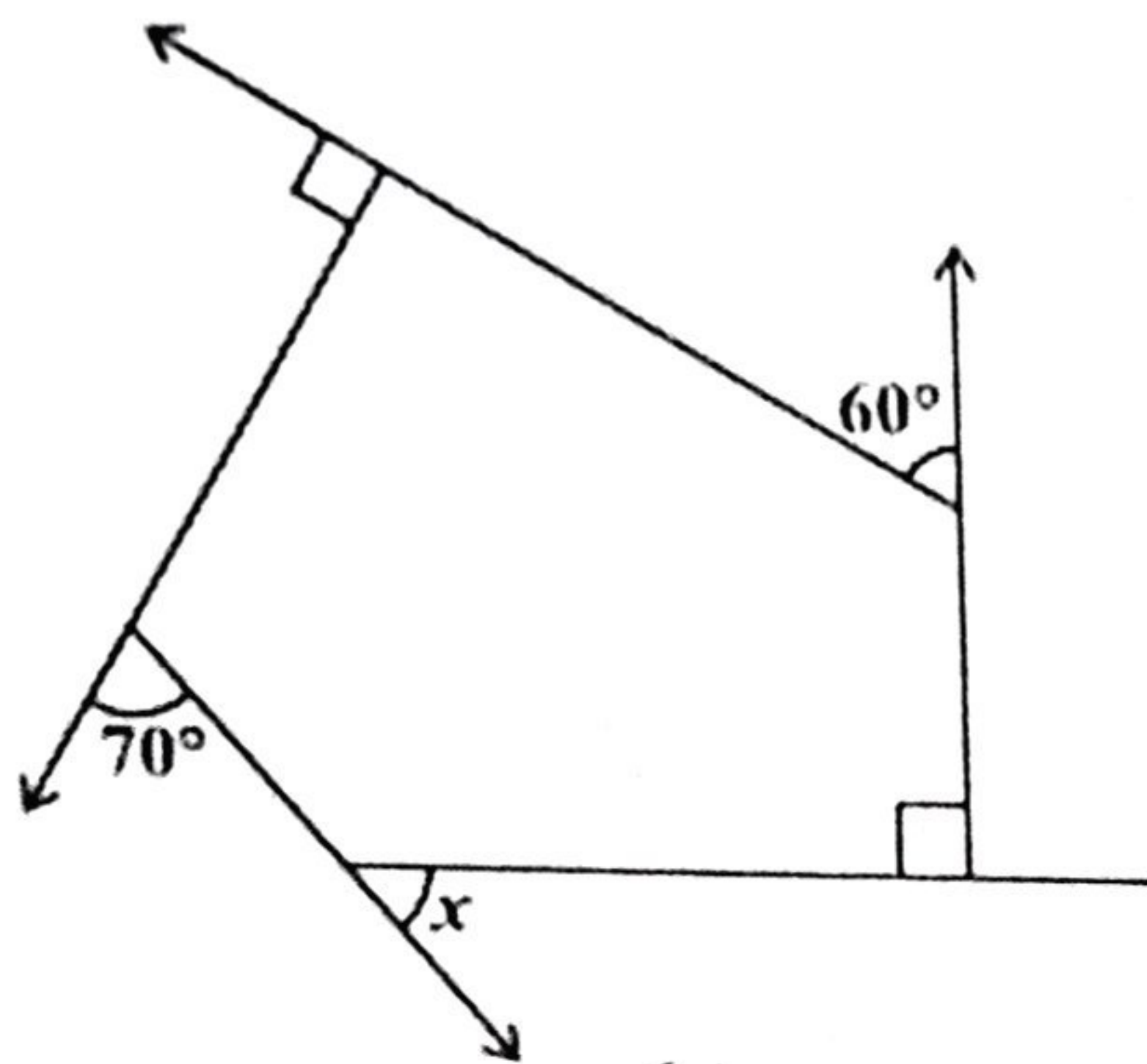
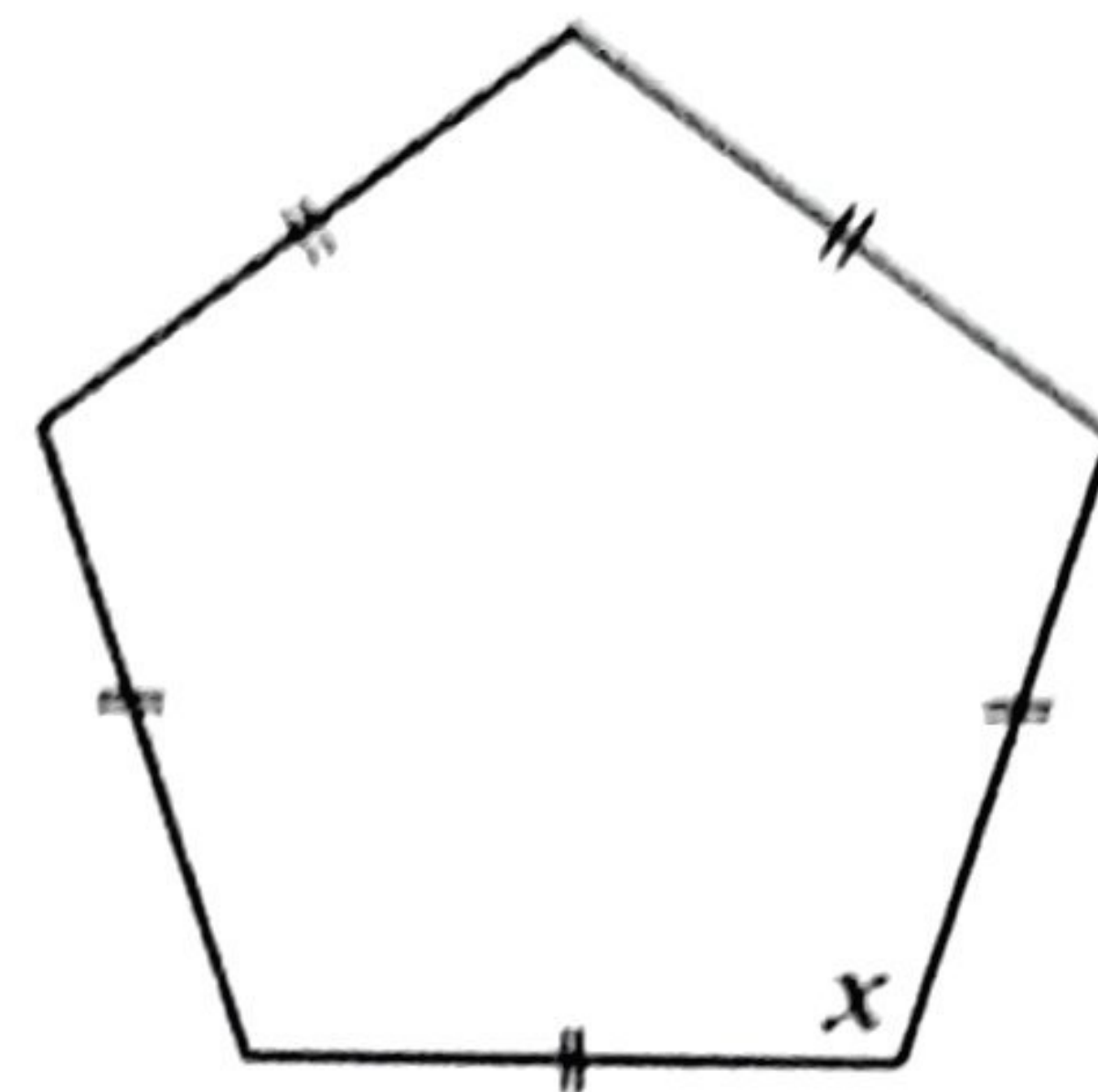
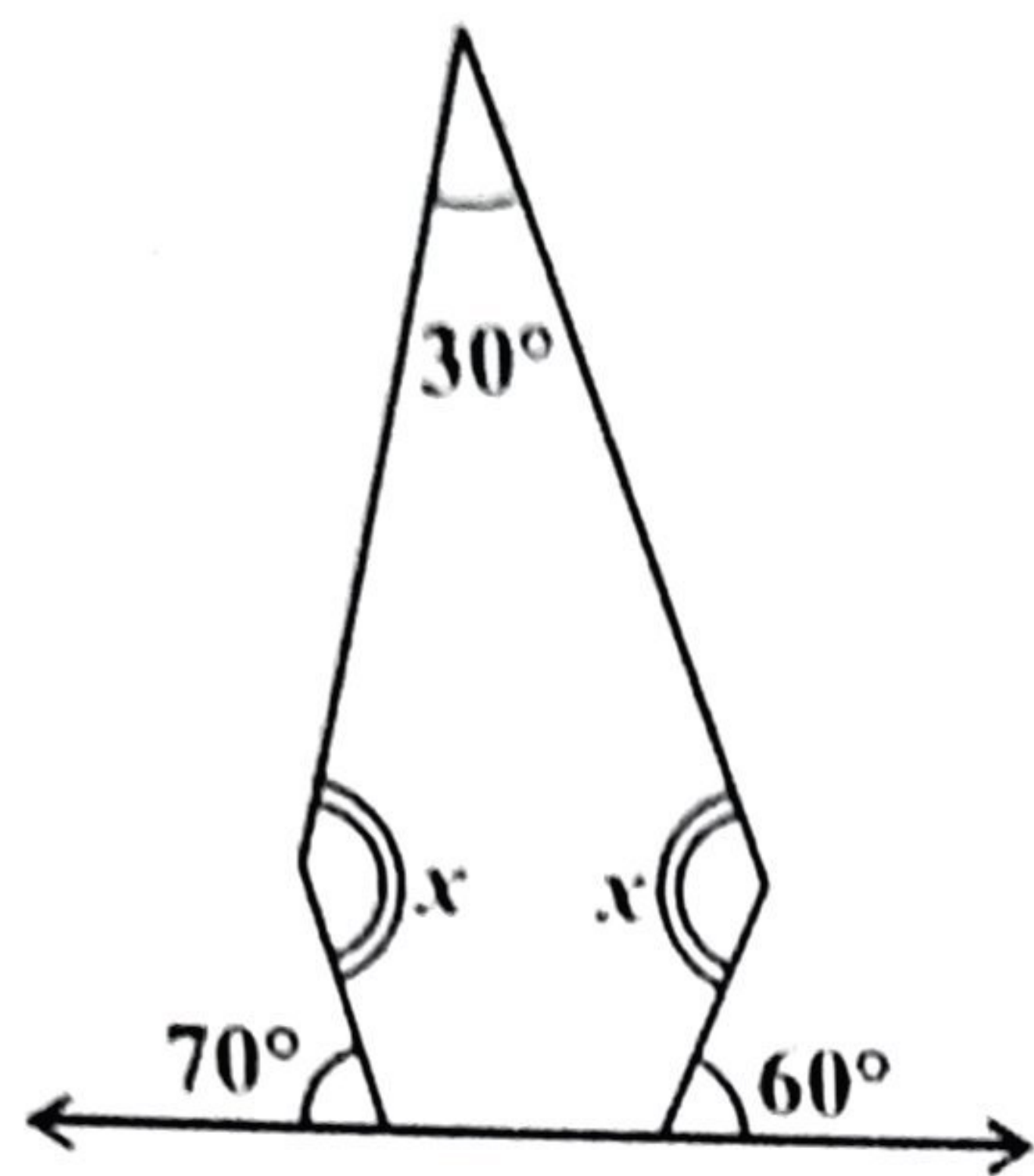

Q16. Explain why a rectangle is a convex quadrilateral.

Q17. Explain how a square is.

(i) a quadrilateral (ii) a parallelogram (iii) a rhombus (iv) a rectangle

Q18. State whether True or False.

(a) All rectangles are squares (e) All kites are rhombuses.

(b) All rhombuses are parallelograms (f) All rhombuses are kites.

(c) All squares are rhombuses and also rectangles (g) All parallelograms are trapeziums.

(d) All squares are not parallelograms. (h) All squares are trapeziums.

Q19. Draw a rough figure of a quadrilateral that is not a parallelogram but has exactly two opposite angles of equal measure.

Q20. The following figures GUNS and RUNS are parallelograms.

Find  $x$  and  $y$ . (Lengths are in cm)

**Holiday Homework ( 23-24)**

**Class- 8**

**Subject -Science**

1. Describe about any five millets in terms of
    - i) Agriculture conditions of production (water need ,temperature ,season and place /state)
    - ii) Nutritional value
    - iii) collect small sample of each millet
  
  2. Describe about five harvesting festivals of India in terms of
    - i) Crop associated with that festival ii) State/ place of festival
    - iii) The picture of festival
    - iv) Significance of celebration of such festivals.
  
  3. Write short note on scientific contributions made by **any three** of the following scientists (paste picture of scientist and about their work ) *(max-100 words each)*
    - 1) Louis Pasteur
    - 2) Alexander Fleming
    - 3) Edward Jenner
    - 4) Robert Hook
  
  4. Take help of your parents to find out your vaccination card and observe it carefully. Then make an observation table to show the following points .
    - i) Name of vaccine
    - ii) Age, when administered to you
    - iii) Targeted disease.
    - iv) Write brief note about the significance of vaccination programs run by various government bodies.
  
  5. Germinate any available seed in a pot ( Gram, Rajma) . Observe the growth and click pics of various stages.
- OR**
- Collect the labels from the bottles of Jams and jellies( Atleast 3). write down the list of contents printed on the label .

-----X-----X-----X-----X-----

ग्रीष्मकालीनअवकाशगृहकार्य

वर्ष -2023-24

कक्षा- अष्टमी (8)

विषय- संस्कृतम्

1.प्रथमपाठस्य श्लोकान्स्मृत्वा स्वअभ्यासपुस्तिकायां लिखत।

(प्रथमपाठ के श्लोकों को याद करके अपनी अभ्यासपुस्तिका में लिखिए)

2-महाकवि कालीदास .संसर्गस्य प्रभाव : ,मम विद्यालय : इति -विषये पञ्च -पञ्च वाक्यानि लिखत।

(महाकवि कालीदास .संसर्गस्य प्रभाव ,मेरा विद्यालय केविषय में पांच-पांच वाक्य लिखिए)

3.अस्मद् तथा युष्मद् शब्दस्य रूपम् स्मरत लिखत च ।

{अस्मद् तथा युष्मद् शब्दरूप याद करें तथा लिखें }

4- संस्कृत भाषायाम प्रार्थना ,प्रतिज्ञा स्मरत लिखत च ।

( संस्कृत भाषा में प्रार्थना तथा प्रतिज्ञा याद करें तथा लिखें )

द्वारा – जयंती सयाना